

**HURRICANE PAD - SOUTH FLORIDA
HIGH WIND ZONE T - CLASS
(MIAMI DADE, BROWARD AND PALM BEACH COUNTIES)**

5523 WEST CYPRESS STREET
SUITE 200
TAMPA, FLORIDA 33607
CA: 8426

CLIENT: DIVERSITECH
PROJECT: WIND ANALYSIS OF 4" HURRICANE PADS MAX. WIND SPEED 175 MPH
CODES: FLORIDA BUILDING CODE 2010
ASCE 7-10
RISK CATEGORY = II
MIAMI DADE COUNTY BASIC WIND SPEED = 175 MPH
BROWARD COUNTY BASIC WIND SPEED = 170 MPH
USE A BASIC WIND SPEED OF 175 MPH

JAMES R. MEHLTRETTER, P.E.
FL # 33860

April 16, 2012

Kz= 0.85 Exposure C ; Table 28.3-1
Kd= 0.85 Table 26.6-1
Kzt= 1.00 Figure 26.8-1

Wind Speed V=	175.00		
qz= 0.00256*Kz*Kzt*Kd*V ²	56.57	PSF	1/4" DIA. TAPCON SCREW 1" EMB
Fh= qz*G*Af (Eq. 29.5-2)			
G= 0.85			PULLOUT = 1140# ULT
Cf= (Figure 29.5-1)	1.30		PULLOUT = 285# SERVICE
Wind Pressure	62.51	PSF	INSTALL SCREWS THROUGH UNIT BASE 22 GAUGE MINIMUM USING HC-1 HURRICANE CLIPS (8 TOTAL)
Fh= Wind Pressure *Ah			See Tables
Ah = L x H			See Tables

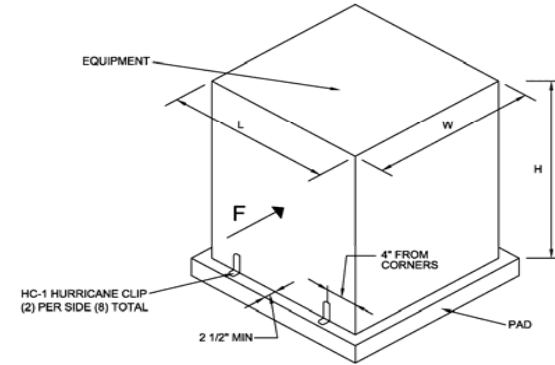

- NOTES:**
- LOAD COMBINATION ASD PER 2.4.1 ASCE 7-10
0.6 x DEAD + 0.6 x WIND (ASCE 7-10; 2.4.1)
 - DESIGN IS BASED ON SECTION 29.5 OF ASCE 7-10 "OTHER STRUCTURES"
UNITS ARE TO BE LOCATED ON THE GROUND.
 - ALL OTHER UNITS NOT SHOWN MUST BE DESIGNED ON A
CASE BY CASE BASIS.
 - LARGER HURRICANE PAD USED IN SOME COMBINATIONS TO SATISFY
DESIGN CHECK.
 - WIND PRESSURE ON UNITS IN ACCORDANCE WITH ASCE 7-10 FIGURE 29.5-1
 - ORIGINAL EQUIPMENT MANUFACTURER INSTALLATION INSTRUCTIONS
SUPERSEDE HURRICANE PAD INSTALLATION INSTRUCTIONS
IF MORE STRINGENT.

T CLASS HURRICANE PAD 4 INCHES THICK

WIND SPEED	Pressure	MODEL #	WEIGHT	L	W
175.00	62.51 PSF	HT3030-4	127	30	30
		HT3648-4	250	36	48
		HT3636-4	180	36	36
		HT2436-4	120	24	36
		HT1840-4	160	18	40
		HT2424-4	85	24	24
		HT3232-4	165	32	32
		HT3345-4	215	33	45
		HT4040-4	260	40	40
		HT4242-4	265	42	42
		HT4558-4	350	45	58
		HT3852-4	265	38	52

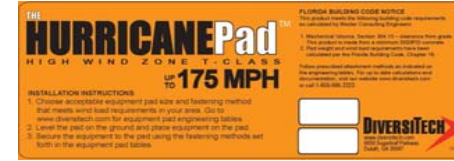

	MAXIMUM UNIT DIMENSIONS			MINIMUM WEIGHT POUNDS	PAD MODEL NUMBER	PAD WEIGHT #	0.6x(UNIT + PAD) WEIGHT		.6xWIND		REMARKS	Allowable Pressure qz PSF	Allowable Wind Speed V MPH		
	W	L	H				ASD DEAD LOAD MOMENT FT-#	F	ASD DESIGN WIND MOMENT FT-#	SF				DESIGN CHECK	
								#		OVERTURN					
	23.125	23.125	26.000	107	HT3030-4	127	140	175.50	261.00	169.65	1.03	OK	OK FOR 175 MPH	64.7	178
	23.125	23.125	26.000	110	HT3030-4	127	142	177.75	261.00	169.65	1.05	OK	OK FOR 175 MPH	65.5	179
	23.125	23.125	28.660	111	HT3232-4	165	166	220.80	287.71	206.14	1.07	OK	OK FOR 175 MPH	67.0	181
	25.750	25.750	32.330	150	HT3636-4	180	198	297.00	361.39	292.09	1.02	OK	OK FOR 175 MPH	63.6	176
	26.200	26.200	35.000	215	HT3636-4	180	237	355.50	398.07	348.31	1.02	OK	OK FOR 175 MPH	63.8	177
	31.200	31.200	35.750	186	HT4040-4	260	268	446.00	484.20	432.75	1.03	OK	OK FOR 175 MPH	64.4	178
	26.200	26.200	33.000	166	HT3636-4	180	208	311.40	375.32	309.64	1.01	OK	OK FOR 175 MPH	62.9	175
	25.750	25.750	31.000	125	HT3636-4	180	183	274.50	346.52	268.55	1.02	OK	OK FOR 175 MPH	63.9	177
	31.200	31.200	34.000	153	HT4040-4	260	248	413.00	460.49	391.42	1.06	OK	OK FOR 175 MPH	66.0	180
	35.000	35.000	31.500	122	HT4040-4	260	229	382.00	478.60	376.90	1.01	OK	OK FOR 175 MPH	63.4	176
	35.000	35.000	38.250	265	HT4242-4	265	318	556.50	581.15	555.73	1.00	OK	OK FOR 175 MPH	62.6	175
	35.000	35.000	39.000	286	HT4242-4	265	331	578.55	592.55	577.73	1.00	OK	OK FOR 175 MPH	62.6	175
	35.000	35.000	41.000	380	HT4040-4	260	384	640.00	622.94	638.51	1.00	OK	OK FOR 175 MPH	62.7	175
	35.000	35.000	45.000	515	HT4040-4	260	465	775.00	683.71	769.17	1.01	OK	OK FOR 175 MPH	63.0	176
	24.750	24.750	28.688	136	HT3232-4	165	181	240.80	308.22	221.05	1.09	OK	OK FOR 175 MPH	68.1	183
	31.200	31.200	35.000	167	HT4040-4	260	256	427.00	474.04	414.78	1.03	OK	OK FOR 175 MPH	64.4	177
	31.200	35.000	31.000	122	HT4040-4	260	229	382.00	471.00	365.03	1.05	OK	OK FOR 175 MPH	65.4	179
	35.000	35.000	39.125	290	HT4242-4	265	333	582.75	594.45	581.44	1.00	OK	OK FOR 175 MPH	62.7	175
	35.000	35.000	34.000	200	HT4040-4	260	276	460.00	516.58	439.09	1.05	OK	OK FOR 175 MPH	65.5	179
	35.000	35.000	41.000	345	HT4242-4	265	366	640.50	622.94	638.51	1.00	OK	OK FOR 175 MPH	62.7	175
	35.000	35.000	44.000	440	HT4242-4	265	423	740.25	668.52	735.37	1.01	OK	OK FOR 175 MPH	62.9	175

**HURRICANE PAD - SOUTH FLORIDA
HIGH WIND ZONE T - CLASS
(MIAMI DADE, BROWARD AND PALM BEACH COUNTIES)**

5523 WEST CYPRESS STREET
SUITE 200
TAMPA, FLORIDA 33607
CA: 8426

CLIENT: DIVERSITECH
PROJECT: WIND ANALYSIS OF 4" HURRICANE PADS MAX. WIND SPEED 175 MPH
CODES: FLORIDA BUILDING CODE 2010
ASCE 7-10
RISK CATEGORY = II
MIAMI DADE COUNTY BASIC WIND SPEED = 175 MPH
BROWARD COUNTY BASIC WIND SPEED = 170 MPH
USE A BASIC WIND SPEED OF 175 MPH

JAMES R. MEHLTRETTER, P.E.
FL # 33860
April 16, 2012

Kz= 0.85 Exposure C ; Table 28.3-1
Kd= 0.85 Table 26.6-1
Kzt= 1.00 Figure 26.8-1

Wind Speed V=	175.00		
qz= 0.00256*Kz*Kzt*Kd*V ²	56.57	PSF	1/4" DIA. TAPCON SCREW 1" EMB
Fh= qz*G*Af (Eq. 29.5-2)			
G= 0.85			PULLOUT = 1140# ULT
Cf= (Figure 29.5-1)	1.30		PULLOUT = 285# SERVICE
Wind Pressure	62.51	PSF	INSTALL SCREWS THROUGH UNIT BASE 22 GAUGE MINIMUM USING HC-1 HURRICANE CLIPS (8 TOTAL)
Fh= Wind Pressure *Ah		See Tables	
Ah = L x H		See Tables	

T CLASS HURRICANE PAD 4 INCHES THICK

WIND SPEED	Pressure	MODEL #	WEIGHT	L	W
175.00	62.51 PSF	HT3030-4	127	30	30
		HT3648-4	250	36	48
		HT3636-4	180	36	36
		HT2436-4	120	24	36
		HT1840-4	160	18	40
		HT2424-4	85	24	24
		HT3232-4	165	32	32
		HT3345-4	215	33	45
		HT4040-4	260	40	40
		HT4242-4	265	42	42
		HT4558-4	350	45	58
		HT3852-4	265	38	52

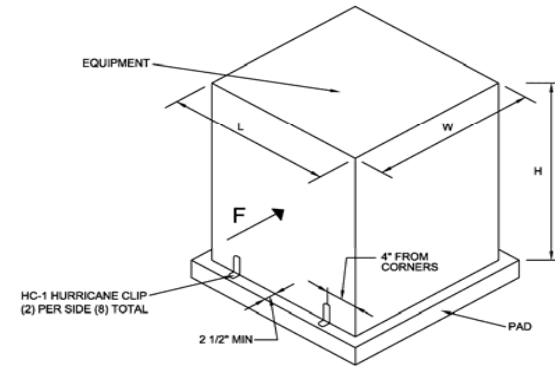

- NOTES:**
- LOAD COMBINATION ASD PER 2.4.1 ASCE 7-10
0.6 x DEAD + 0.6 x WIND (ASCE 7-10; 2.4.1)
 - DESIGN IS BASED ON SECTION 29.5 OF ASCE 7-10 "OTHER STRUCTURES"
UNITS ARE TO BE LOCATED ON THE GROUND.
 - ALL OTHER UNITS NOT SHOWN MUST BE DESIGNED ON A
CASE BY CASE BASIS.
 - LARGER HURRICANE PAD USED IN SOME COMBINATIONS TO SATISFY
DESIGN CHECK.
 - WIND PRESSURE ON UNITS IN ACCORDANCE WITH ASCE 7-10 FIGURE 29.5-1
 - ORIGINAL EQUIPMENT MANUFACTURER INSTALLATION INSTRUCTIONS
SUPERSEDE HURRICANE PAD INSTALLATION INSTRUCTIONS
IF MORE STRINGENT.

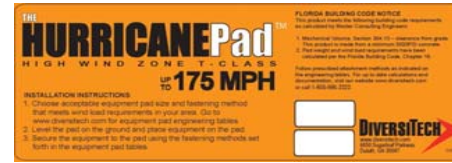

	MAXIMUM UNIT DIMENSIONS			MINIMUM WEIGHT POUNDS	PAD MODEL NUMBER	PAD WEIGHT #	0.6x(UNIT + PAD) WEIGHT		.6xWIND		REMARKS	Allowable Pressure qz PSF	Allowable Wind Speed V MPH		
	W	L	H				ASD DEAD LOAD MOMENT FT-#	F	ASD DESIGN WIND MOMENT FT-#	SF				DESIGN CHECK	
										OVERTURN					
	31.200	31.200	39.125	285	HT4040-4	260	327	545.00	529.91	518.32	1.05	OK	OK FOR 175 MPH	65.7	179
	35.000	35.000	39.125	324	HT4040-4	260	350	584.00	594.45	581.44	1.00	OK	OK FOR 175 MPH	62.8	175
	35.000	35.000	42.000	374	HT4242-4	265	383	670.95	638.13	670.04	1.00	OK	OK FOR 175 MPH	62.6	175
	35.000	35.000	44.000	437	HT4242-4	265	421	737.10	668.52	735.37	1.00	OK	OK FOR 175 MPH	62.7	175
	29.250	33.000	41.000	198	HT4558-4	350	329	616.50	587.34	602.02	1.02	OK	OK FOR 175 MPH	64.0	177
	35.500	40.000	38.000	248	HT4558-4	350	359	672.75	659.83	626.84	1.07	OK	OK FOR 175 MPH	67.1	181
	35.500	40.000	44.000	400	HT4558-4	350	450	843.75	764.02	840.42	1.00	OK	OK FOR 175 MPH	62.8	175
	35.500	40.000	47.333	520	HT4558-4	350	522	978.75	821.90	972.58	1.01	OK	OK FOR 175 MPH	62.9	175
	31.200	31.200	39.125	270	HT4040-4	260	318	530.00	529.91	518.32	1.02	OK	OK FOR 175 MPH	63.9	177
	35.000	35.000	39.125	324	HT4040-4	260	350	584.00	594.45	581.44	1.00	OK	OK FOR 175 MPH	62.8	175
	35.000	35.000	46.000	370	HT4558-4	350	432	810.00	698.90	803.74	1.01	OK	OK FOR 175 MPH	63.0	176
	35.000	35.000	45.875	370	HT4558-4	350	432	810.00	697.00	799.38	1.01	OK	OK FOR 175 MPH	63.3	176
	35.500	37.000	41.000	380	HT4242-4	265	387	677.25	658.53	675.00	1.00	OK	OK FOR 175 MPH	62.7	175
	35.500	37.000	43.000	445	HT4242-4	265	426	745.50	690.66	742.45	1.00	OK	OK FOR 175 MPH	62.8	175
	35.500	40.000	44.000	400	HT4558-4	350	450	843.75	764.02	840.42	1.00	OK	OK FOR 175 MPH	62.8	175
	35.500	40.000	46.000	468	HT4558-4	350	491	920.25	798.75	918.56	1.00	OK	OK FOR 175 MPH	62.6	175
	25.000	25.000	26.000	127	HT3030-4	127	152	190.50	282.17	183.41	1.04	OK	OK FOR 175 MPH	64.9	178
	25.750	25.750	32.313	150	HT3636-4	180	198	297.00	361.19	291.78	1.02	OK	OK FOR 175 MPH	63.6	176
	26.200	26.200	30.000	115	HT3636-4	180	177	265.50	341.20	255.90	1.04	OK	OK FOR 175 MPH	64.9	178
	31.200	31.200	34.000	152	HT4040-4	260	247	412.00	460.49	391.42	1.05	OK	OK FOR 175 MPH	65.8	179
	31.200	31.200	35.750	216	HT4040-4	260	286	476.00	484.20	432.75	1.10	OK	OK FOR 175 MPH	68.8	183

**HURRICANE PAD - SOUTH FLORIDA
HIGH WIND ZONE T - CLASS
(MIAMI DADE, BROWARD AND PALM BEACH COUNTIES)**

5523 WEST CYPRESS STREET
SUITE 200
TAMPA, FLORIDA 33607
CA: 8426

CLIENT: DIVERSITECH
PROJECT: WIND ANALYSIS OF 4" HURRICANE PADS MAX. WIND SPEED 175 MPH
CODES: FLORIDA BUILDING CODE 2010
ASCE 7-10
RISK CATEGORY = II
MIAMI DADE COUNTY BASIC WIND SPEED = 175 MPH
BROWARD COUNTY BASIC WIND SPEED = 170 MPH
USE A BASIC WIND SPEED OF 175 MPH

JAMES R. MEHLTRETTER, P.E.
FL # 33860
April 16, 2012

Kz= 0.85 Exposure C ; Table 28.3-1
Kd= 0.85 Table 26.6-1
Kzt= 1.00 Figure 26.8-1

Wind Speed V=	175.00		
qz= 0.00256*Kz*Kzt*Kd*V ² /2	56.57	PSF	1/4" DIA. TAPCON SCREW 1" EMB
Fh= qz*G*Cf*Af (Eq. 29.5-2)			PULLOUT = 1140# ULT
G= 0.85			PULLOUT = 285# SERVICE
Cf= (Figure 29.5-1)			INSTALL SCREWS THROUGH UNIT BASE 22 GAUGE MINIMUM USING HC-1 HURRICANE CLIPS (8 TOTAL)
Wind Pressure	62.51	PSF	
Fh= Wind Pressure *Ah			See Tables
Ah = L x H			See Tables

T CLASS HURRICANE PAD 4 INCHES THICK

WIND SPEED	Pressure	MODEL #	WEIGHT	L	W
175.00	62.51 PSF	HT3030-4	127	30	30
		HT3648-4	250	36	48
		HT3636-4	180	36	36
		HT2436-4	120	24	36
		HT1840-4	160	18	40
		HT2424-4	85	24	24
		HT3232-4	165	32	32
		HT3345-4	215	33	45
		HT4040-4	260	40	40
		HT4242-4	265	42	42
		HT4558-4	350	45	58
		HT3852-4	265	38	52

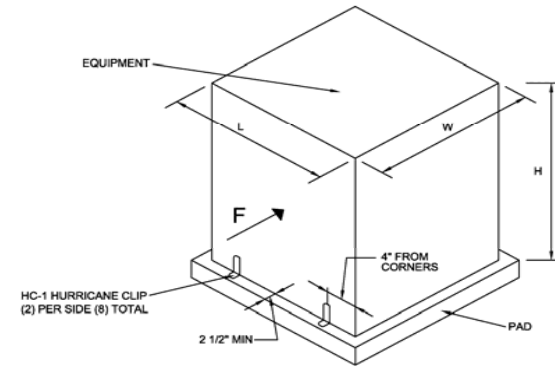

- NOTES:**
- LOAD COMBINATION ASD PER 2.4.1 ASCE 7-10
0.6 x DEAD + 0.6 x WIND (ASCE 7-10; 2.4.1)
 - DESIGN IS BASED ON SECTION 29.5 OF ASCE 7-10 "OTHER STRUCTURES"
UNITS ARE TO BE LOCATED ON THE GROUND.
 - ALL OTHER UNITS NOT SHOWN MUST BE DESIGNED ON A
CASE BY CASE BASIS.
 - LARGER HURRICANE PAD USED IN SOME COMBINATIONS TO SATISFY
DESIGN CHECK.
 - WIND PRESSURE ON UNITS IN ACCORDANCE WITH ASCE 7-10 FIGURE 29.5-1
 - ORIGINAL EQUIPMENT MANUFACTURER INSTALLATION INSTRUCTIONS
SUPERSEDE HURRICANE PAD INSTALLATION INSTRUCTIONS
IF MORE STRINGENT.

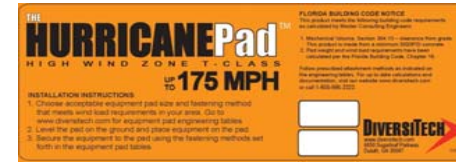

	MAXIMUM UNIT DIMENSIONS			MINIMUM WEIGHT POUNDS	PAD MODEL NUMBER	PAD WEIGHT #	0.6x(UNIT + PAD) WEIGHT		.6xWIND		REMARKS		Allowable Pressure qz PSF	Allowable Wind Speed V MPH	
	W	L	H				ASD DEAD LOAD MOMENT FT-#	F	ASD DESIGN WIND MOMENT FT-#	OVERTURN CHECK					
	35.000	35.000	34.500	200	HT4040-4	260	276	460.00	524.18	452.10	1.02	OK	OK FOR 175 MPH	63.6	176
	35.000	35.000	36.000	235	HT4040-4	260	297	495.00	546.97	492.27	1.01	OK	OK FOR 175 MPH	62.9	175
	35.000	35.000	37.500	280	HT4040-4	260	324	540.00	569.76	534.15	1.01	OK	OK FOR 175 MPH	63.2	176
	35.000	35.000	39.125	325	HT4040-4	260	351	585.00	594.45	581.44	1.01	OK	OK FOR 175 MPH	62.9	175
	31.200	31.200	37.000	206	HT4040-4	260	280	466.00	501.13	463.54	1.01	OK	OK FOR 175 MPH	62.8	175
	35.000	35.000	34.000	203	HT4040-4	260	278	463.00	516.58	439.09	1.05	OK	OK FOR 175 MPH	65.9	180
	35.000	35.000	39.125	340	HT4040-4	260	360	600.00	594.45	581.44	1.03	OK	OK FOR 175 MPH	64.5	178
	26.200	26.200	33.000	169	HT3636-4	180	209	314.10	375.32	309.64	1.01	OK	OK FOR 175 MPH	63.4	176
	35.000	35.000	34.000	190	HT4040-4	260	270	450.00	516.58	439.09	1.02	OK	OK FOR 175 MPH	64.1	177
	35.000	35.000	35.000	215	HT4040-4	260	285	475.00	531.77	465.30	1.02	OK	OK FOR 175 MPH	63.8	177
	35.000	35.000	33.000	160	HT4040-4	260	252	420.00	501.39	413.64	1.02	OK	OK FOR 175 MPH	63.5	176
	35.000	35.000	38.000	294	HT4040-4	260	332	554.00	577.36	548.49	1.01	OK	OK FOR 175 MPH	63.1	176
														0.0	0
	35.000	35.000	37.000	281	HT4040-4	260	325	541.00	562.16	520.00	1.04	OK	OK FOR 175 MPH	65.0	178
	35.000	35.000	39.125	330	HT4040-4	260	354	590.00	594.45	581.44	1.01	OK	OK FOR 175 MPH	63.4	176
	35.000	35.000	45.000	349	HT4558-4	350	419	786.38	683.71	769.17	1.02	OK	OK FOR 175 MPH	63.9	177
														0.0	0

**HURRICANE PAD - SOUTH FLORIDA
HIGH WIND ZONE T - CLASS
(MIAMI DADE, BROWARD AND PALM BEACH COUNTIES)**

5523 WEST CYPRESS STREET
SUITE 200
TAMPA, FLORIDA 33607
CA: 8426

CLIENT: DIVERSITECH
PROJECT: WIND ANALYSIS OF 4" HURRICANE PADS MAX. WIND SPEED 175 MPH
CODES: FLORIDA BUILDING CODE 2010
ASCE 7-10
RISK CATEGORY = II
MIAMI DADE COUNTY BASIC WIND SPEED = 175 MPH
BROWARD COUNTY BASIC WIND SPEED = 170 MPH
USE A BASIC WIND SPEED OF 175 MPH

JAMES R. MEHLTRETTER, P.E.
FL # 33860
April 16, 2012

Kz= 0.85 Exposure C ; Table 28.3-1
Kd= 0.85 Table 26.6-1
Kzt= 1.00 Figure 26.8-1

Wind Speed V=	175.00		
qz= 0.00256*Kz*Kzt*Kd*V ² /2	56.57	PSF	1/4" DIA. TAPCON SCREW 1" EMB
Fh= qz*G*Cl*Af (Eq. 29.5-2)			
G= 0.85			PULLOUT = 1140# ULT
Cl= (Figure 29.5-1)			PULLOUT = 285# SERVICE
Wind Pressure	62.51	PSF	INSTALL SCREWS THROUGH UNIT BASE 22 GAGE MINIMUM USING HC-1 HURRICANE CLIPS (8 TOTAL)
Fh= Wind Pressure *Ah		See Tables	
Ah = L x H		See Tables	

T CLASS HURRICANE PAD 4 INCHES THICK

WIND SPEED	Pressure	MODEL #	WEIGHT	L	W
175.00	62.51 PSF	HT3030-4	127	30	30
		HT3648-4	250	36	48
		HT3636-4	180	36	36
		HT2436-4	120	24	36
		HT1840-4	160	18	40
		HT2424-4	85	24	24
		HT3232-4	165	32	32
		HT3345-4	215	33	45
		HT4040-4	260	40	40
		HT4242-4	265	42	42
		HT4558-4	350	45	58
		HT3852-4	265	38	52

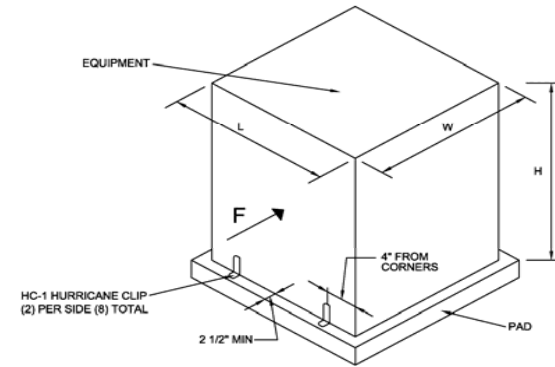

- NOTES:**
- LOAD COMBINATION ASD PER 2.4.1 ASCE 7-10
0.6 x DEAD + 0.6 x WIND (ASCE 7-10; 2.4.1)
 - DESIGN IS BASED ON SECTION 29.5 OF ASCE 7-10 "OTHER STRUCTURES"
UNITS ARE TO BE LOCATED ON THE GROUND.
 - ALL OTHER UNITS NOT SHOWN MUST BE DESIGNED ON A
CASE BY CASE BASIS.
 - LARGER HURRICANE PAD USED IN SOME COMBINATIONS TO SATISFY
DESIGN CHECK.
 - WIND PRESSURE ON UNITS IN ACCORDANCE WITH ASCE 7-10 FIGURE 29.5-1
 - ORIGINAL EQUIPMENT MANUFACTURER INSTALLATION INSTRUCTIONS
SUPERSEDE HURRICANE PAD INSTALLATION INSTRUCTIONS
IF MORE STRINGENT.



	MAXIMUM UNIT DIMENSIONS			MINIMUM WEIGHT POUNDS	PAD MODEL	PAD WEIGHT #	0.6x(UNIT + PAD) WEIGHT		.6xWIND		REMARKS	Allowable Pressure qz PSF	Allowable Wind Speed V MPH		
	W	L	H				6xDEAD ASD DEAD LOAD MOMENT FT-#	F	ASD DESIGN WIND MOMENT SF	DESIGN OVERTURN CHECK					
	35.500	40.000	35.000	130	HT4558-4	350	288	540.00	607.74	531.77	1.02	OK	OK FOR 175 MPH	63.5	176
	35.500	40.000	38.000	230	HT4558-4	350	348	652.50	659.83	626.84	1.04	OK	OK FOR 175 MPH	65.1	178
	35.500	40.000	40.500	289	HT4558-4	350	383	718.88	703.24	712.04	1.01	OK	OK FOR 175 MPH	65.2	179
	35.500	40.000	42.000	360	HT4558-4	350	426	798.75	729.29	765.76	1.04	OK	OK FOR 175 MPH	64.6	178
	35.500	40.000	44.000	422	HT4558-4	350	463	868.50	764.02	840.42	1.03	OK	OK FOR 175 MPH	0.0	0
	35.000	35.000	35.750	240	HT4040-4	260	300	500.00	543.17	485.46	1.03	OK	OK FOR 175 MPH	64.4	177
	35.000	35.000	38.500	310	HT4040-4	260	342	570.00	584.95	563.02	1.01	OK	OK FOR 175 MPH	63.3	176
	35.000	35.000	41.000	349	HT4242-4	265	368	644.70	622.94	638.51	1.01	OK	OK FOR 175 MPH	63.1	176
	35.000	35.000	44.000	440	HT4242-4	265	423	740.25	668.52	735.37	1.01	OK	OK FOR 175 MPH	62.9	175
	35.500	40.000	42.000	343	HT4558-4	350	416	779.63	729.29	765.76	1.02	OK	OK FOR 175 MPH	63.6	176
	35.500	40.000	45.000	450	HT4558-4	350	480	900.00	781.38	879.06	1.02	OK	OK FOR 175 MPH	64.0	177
	33.000	44.000	32.000	255	HT3852-4	265	312	494.00	611.21	488.97	1.01	OK	OK FOR 175 MPH	63.2	176
	33.000	44.000	37.000	250	HT4558-4	350	360	675.00	706.72	653.71	1.03	OK	OK FOR 175 MPH	64.5	178
	33.000	44.000	39.500	326	HT4558-4	350	406	760.50	754.47	745.04	1.02	OK	OK FOR 175 MPH	63.8	177
	31.625	31.625	34.000	157	HT3852-4	265	253	400.90	466.77	396.75	1.01	OK	OK FOR 175 MPH	63.2	176
	31.625	31.625	36.000	205	HT3852-4	265	282	446.50	494.22	444.80	1.00	OK	OK FOR 175 MPH	62.7	175
	31.500	44.375	33.000	300	HT3852-4	265	339	536.75	635.69	524.44	1.02	OK	OK FOR 175 MPH	64.0	177
	31.625	44.375	34.000	326	HT3852-4	265	355	561.45	654.95	556.71	1.01	OK	OK FOR 175 MPH	63.0	176
	13.000	30.000	24.000	260	HT1840-4	160	252	189.00	312.55	187.53	1.01	OK	OK FOR 175 MPH	63.0	176
	13.000	30.000	26.000	340	HT1840-4	160	300	225.00	338.60	220.09	1.02	OK	OK FOR 175 MPH	63.9	177
	13.000	30.000	28.000	440	HT1840-4	160	360	270.00	364.65	255.25	1.06	OK	OK FOR 175 MPH	66.1	180